

TD 8: Partial Order Reductions

1 Ample Sets

Exercise 1 (Ample Sets). Consider the following transition system with state set $S = \{s_0, \dots, s_7\}$ and transition alphabet $\Delta = \{a, b, c, d\}$:

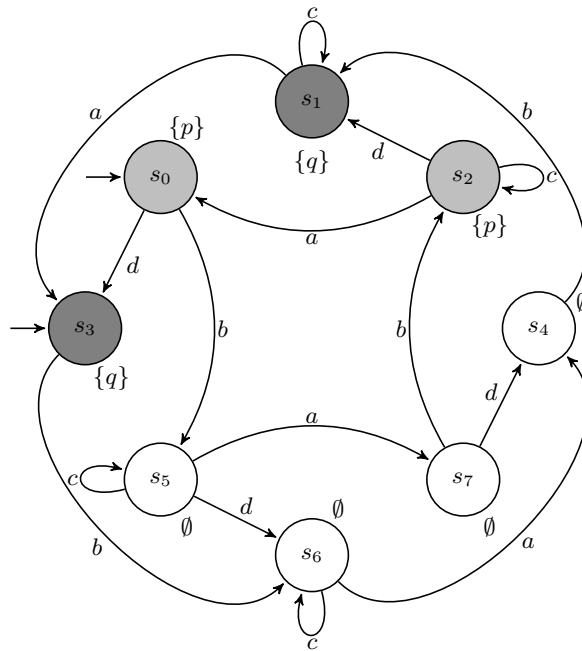

1. Compute the independence set $I \subseteq \Delta^2$.
2. What is the set of invisible actions $U \subseteq \Delta$?
3. Propose an assignment $red : S \rightarrow 2^\Delta$ of ample sets satisfying conditions C_0 – C_3 of the lecture notes.
4. Propose a stutter-equivalent system with a reduced set of states.

Exercise 2 (Alternate conditions).

1. Consider the alternate condition C'_1 : for any s with $red(s) \neq en(s)$, any a in $red(s)$ is independent from every b in $en(s) \setminus red(s)$. Show that C_1 implies C'_1 . Does the converse implication hold? *Hint: consider the following system with $red: s_0 \mapsto \{a\}, s_2 \mapsto \{b\},$ and $s_3 \mapsto \{d\}$.*

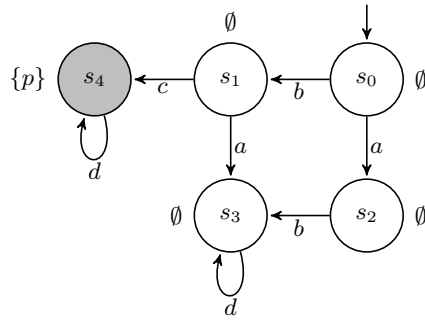

2. Consider the alternate condition C_3'' : any cycle in \mathcal{K}' contains at least one state s with $red(s) = en(s)$. Show that C_0 – C_2 and C_3'' together imply C_3 . Do C_0 – C_3 together imply C_3'' ?

2 Nested DFS

Partial order reduction using ample sets is especially suited for on-the-fly algorithms for the emptiness of Büchi automata. The usual, linear-time algorithm for this task uses a *nested depth-first search*.

Recall a DFS-based algorithm for cycle detection from a given state $s \in S$ in a finite directed graph (Q, T) , with a global variable $V \subseteq Q$ for the set of already visited vertices:

```

1 found ← false                                     /* no cycle found yet */
2 P ← s                                             /* a stack P ∈ Q* of vertices to process */
3 V ← V ∪ {s}                                       /* the set of visited vertices */
4 repeat
5   s' ← top(P)
6   if s ∈ T(s') then
7     found ← true
8     push(s, P)
9   else
10    if T(s') \ V ≠ ∅ then
11      s'' ← some(T(s') \ V)                       /* some vertice accessible from s' */
12      push(s'', P)
13      V ← V ∪ {s''}
14    else
15      pop(P)
16    end
17  end
18 until P = ε ∨ found
19 return found

```

Algorithm 1: CYCLE(s)

One way to use this algorithm for Büchi automata emptiness is to first find the accepting states s in F of the automaton $\mathcal{B} = \langle Q, \Sigma, \delta, I, F \rangle$ that are reachable from I (also by an *external* DFS), and then call `CYCLE(s)` with $V = \emptyset$ for each such state—a quadratic time algorithm. The next exercise refines this approach:

Exercise 3 (Nested DFS). The idea of the nested DFS algorithm is to avoid states from previous cycle searches in latter searches—hence the global V in `CYCLE`. Consider the following external DFS `ACYCLE` that uses a set of visited states U , and calls `CYCLE` on reachable accepting states s' of \mathcal{B} *once their reachable states have been processed* (see line 12).

```

1  $P' \leftarrow s$                                 /* a stack  $P' \in Q^*$  of vertices to process */
2  $U \leftarrow U \cup \{s\}$                        /* the set of visited vertices */
3 repeat
4    $s' \leftarrow \text{top}(P')$ 
5   if  $T(s') \setminus U \neq \emptyset$  then
6      $s'' \leftarrow \text{some}(T(s') \setminus U)$       /* some vertice accessible from  $s'$  */
7      $\text{push}(s'', P')$ 
8      $U \leftarrow U \cup \{s''\}$ 
9   else
10     $\text{pop}(P')$                                 /* all the successors of  $s'$  have been processed */
11    if  $s' \in F$  then
12       $\text{found} \leftarrow \text{CYCLE}(s')$           /* call CYCLE on  $s'$  */
13    end
14  end
15 until  $P' = \varepsilon \vee \text{found}$ 

```

Algorithm 2: `ACYCLE(s)`

1. Consider a call to `ACYCLE(s0)` with empty initial U and V . Assume there exists a call to `CYCLE(s)` performed by `ACYCLE` such that, before the call,

$$\text{there is a cycle } q_0 q_1 \cdots q_k, q_0 = s = q_k \wedge \exists i, q_i \in V ; \quad (\dagger)$$

without loss of generality assume that s is the first state s.t. (\dagger) occurs. Note that there has to be $s' \in Q$ s.t. `CYCLE(s')` was invoked before `CYCLE(s)` and q_i was visited and added to V during this call to `CYCLE(s')`.

- (a) Consider the two cases: s was visited (i.e. pushed on P') before or after s' in the run of `ACYCLE`, and derive a contradiction in both cases.
 - (b) Why does `ACYCLE` succeeds in finding acceptance cycles from s_0 ?
2. Provide the missing invocation context for `ACYCLE` to solve Büchi automata emptiness.
 3. Show that the algorithm works in linear time.

Exercise 4 (Ample Sets in Nested DFS).

1. Assume you are given ample sets for each reachable state (i.e. you can call $red(s)$ for any reachable state s and obtain the ample set for s). Adapt the nested DFS algorithm to only explore the reduced system.
2. Assume now that you are only provided with a $red'(s)$ function that provides ample sets verifying C_0 – C_2 , but not necessarily C_3 . Adapt your algorithm to enforce C_3'' on the fly. How do C_3' and C_3'' compare?

3 CTL(U) Model Checking

Exercise 5 (C_0 – C_3 are not Sufficient). Consider the following system with $\Delta = \{a, b, c, d\}$:

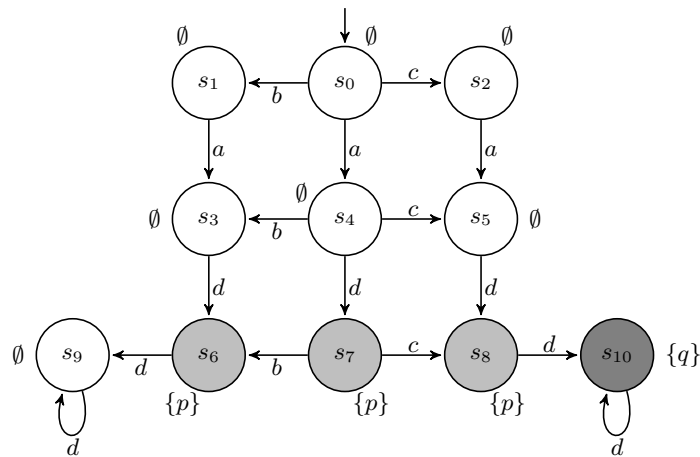

1. Let $red(s_0) = \{b, c\}$ and $red(s) = en(s)$ for $s \neq s_0$; show that this ample set assignment is compatible with C_0 – C_3 .
2. Exhibit a CTL(U) formula that distinguishes between the original system and its reduction.
3. Can you propose an assignment that also complies with C_4 : if $red(s) \neq en(s)$, then $|red(s)| = 1$?